

Technical Data Sheet Hallett 500PN

www.uvpure.com

Potable Water Applications



Model Validation protocol

Hallett 500PN
NSF/ANSI 55 CLASS A
NSF by NSF International

Operating Range

Flow (single unit)	Up to 16.5 US gpm (62.5 lpm)
UV dose	40 mJ/cm ²
UV Transmittance [UVT] (water)	Minimum 75% UVT
Hardness (water)	Maximum 855 mg/L (50 gpg)
Iron (water)	Maximum 3 mg/L (3 ppm)
Temperature (air and water)	34 - 104°F (1 - 40°C)
Water pressure	5 - 100 psig (34 - 690 kPa)
Relative humidity (air)	Maximum 70%

Features

Quartz sleeve cleaning	Built-in - automatic mechanical wiper
Wiper position switch	Built-in
Purge valve	Built-in
Cooling	Built-in - forced air
Flow restrictor	Standard - internal
Shut-off valve	Optional - automatic solenoid

Electrical/Instrumentation

Voltage	120 V AC, 50/60 Hz
Power consumption (nominal)	196 W
Certifications	UL 979
UV lamps	Dual LPHO - air mounted
Lamp life (typical)	9,000 hours
Lamp cycles (recommended)	Maximum 2 per 24 hours
Sensors	Dual UV - calibrated to NIST standards
Dry contacts	Built-in - 2 provided (warning and alarm)
Interface	Colour LCD resistive touchscreen display
Alarming	Indicator light and audible alarms
Remote start/stop	Built-in
Onboard diagnostics	Built-in
4-20mA Output & Modbus	Optional

Physical

Dimensions (H x W x D)	36.5 x 9.6 x 8.6 in (926 x 244 x 218 mm)
Weight (dry)	32 lb (14.6 kg)
Weight (wet)	36 lb (16.3 kg)
Wetted parts	Meets NSF/ANSI 61 & NSF/ANSI 372 for water up to 73°F (23°C)
Body materials	Anodized aluminum and 316 Stainless Steel
Body configuration	Double door with side hinges
Inlet/outlet ports	1" MNPT Stainless Steel, optional - Stainless Steel hose
Ingress Protection rating	IP 51, optional - IP 66 for NEMA cabinet systems
Multiple units	Multiplex manifold and cabinets available
Warranty	5-year limited warranty for structural, hardware and mechanical components; 3-year limited warranty on electrical components and quartz sleeves; 12-month limited warranty on bulbs; and 1-year limited warranty on sensor probes

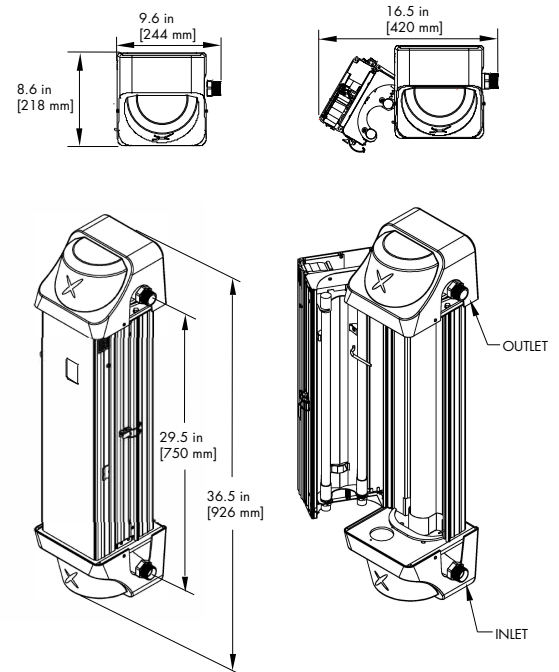

Contact a UV Pure representative to confirm product operating parameters for specific applications.

info@uvpure.com